

COMPARE AND ORDER *By Object Length*

1ST GRADE

Comparing Objects

Name: _____ Date: _____

Directions: Identify the longest object and the shortest object and write its number under longest or shortest.

Which is the longest? Which is the shortest?

1. [Ice cream cones] 2. [Ice cream cones] 3. [Ice cream cones]

2. [Ice cream cones] 1. [Ice cream cones] 3. [Ice cream cones]

3. [Popsicles] 1. [Popsicles] 2. [Popsicles]

4. [Popsicles] 2. [Popsicles] 3. [Popsicles]

5. [Ice cream cones] 1. [Ice cream cones] 2. [Ice cream cones] 3. [Ice cream cones]

CCSS ALIGNED 1.MD.1

FLORIDA B.E.S.T. STANDARDS MA.1.M.1.2

COMPLETE UNIT INCLUDES VIDEO SONG, ANCHOR CHARTS, WORKSHEETS, CENTERS, & ASSESSMENT



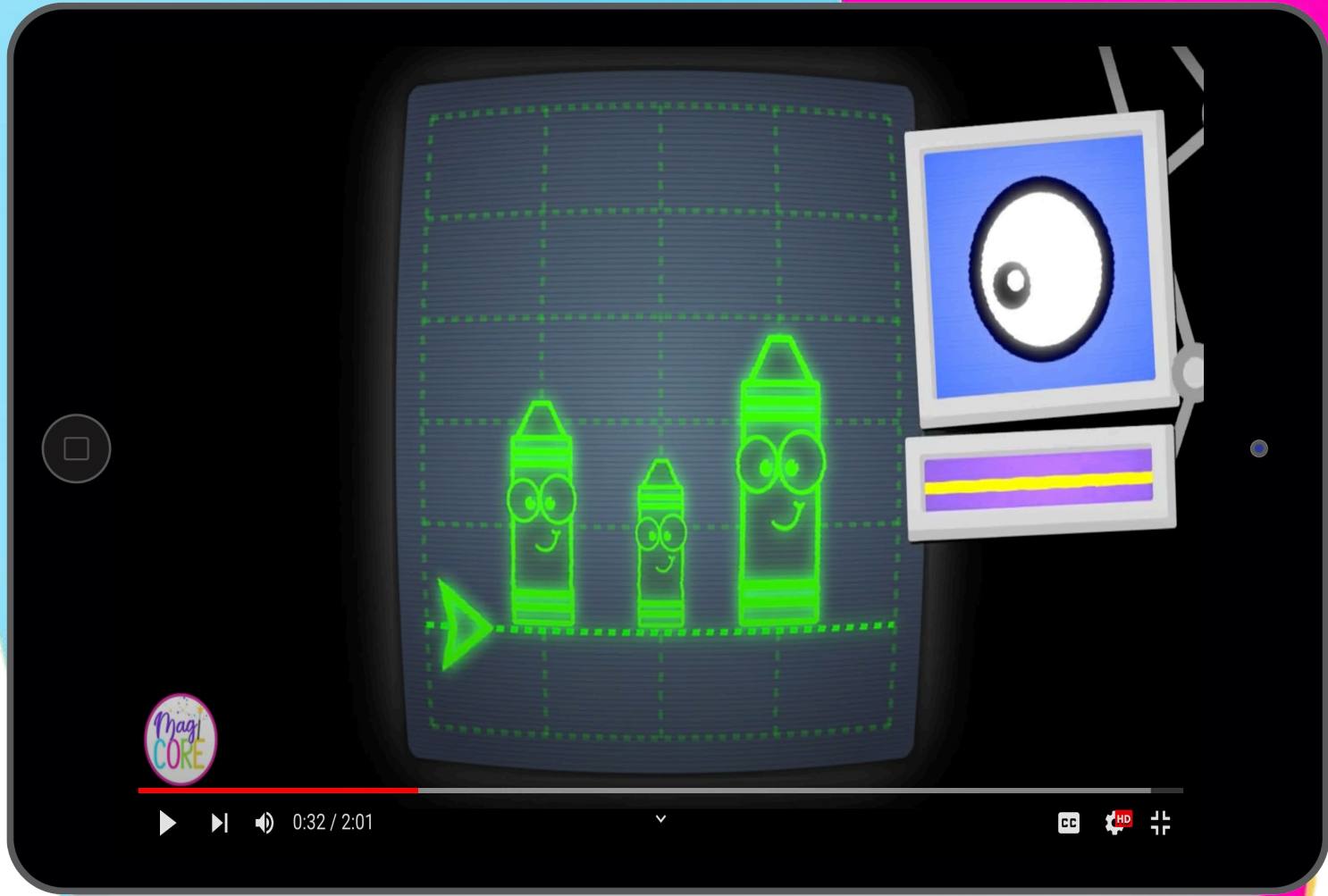

Make Learning Fun!
Original song and
video to introduce and
reinforce the skill.



Compare and Order

When we order objects by length, we have to compare lengths to know how to order them!

COMPARE

- 1 Line everything up at the same endpoint.
- 2 Measure from endpoint to endpoint.

Longest

Shortest

Comparing Objects

Name _____ Date _____

Directions: Identify the longest object and the shortest object. Write its number under longest or shortest.

1	2	3	4	5
1	2	3	4	5
1	2	3	4	5
1	2	3	4	5
1	2	3	4	5

Longest

Shortest

Endpoint

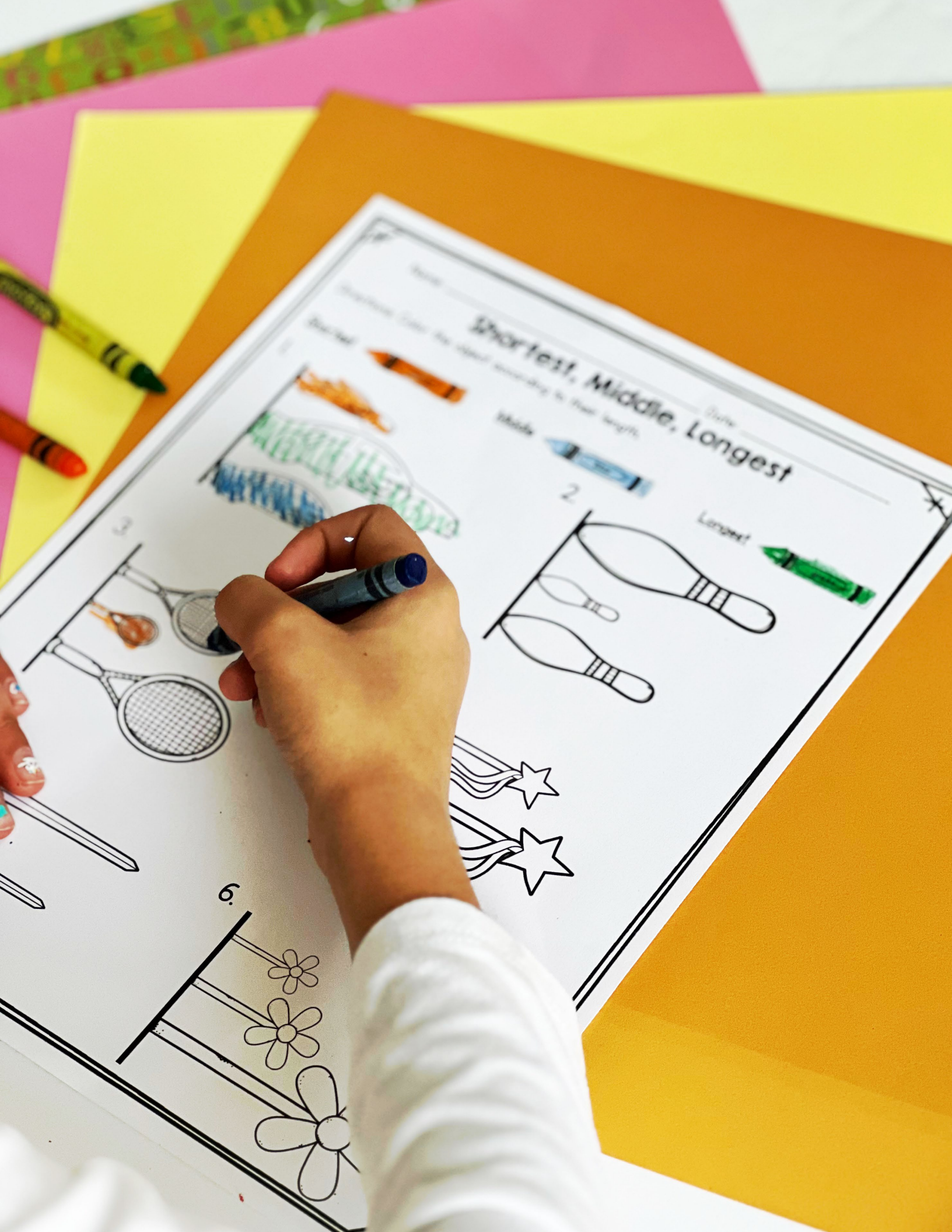

Shortest, Middle, Longest

Order the objects according to their length.

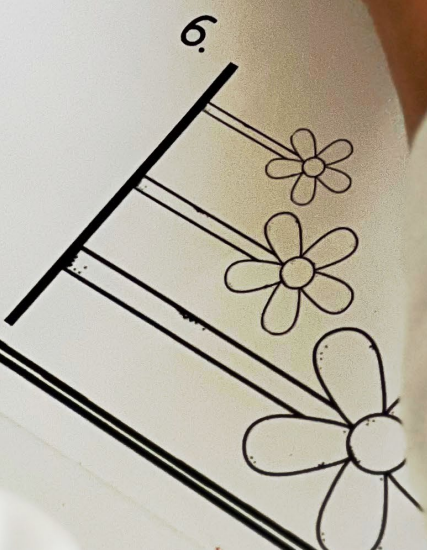
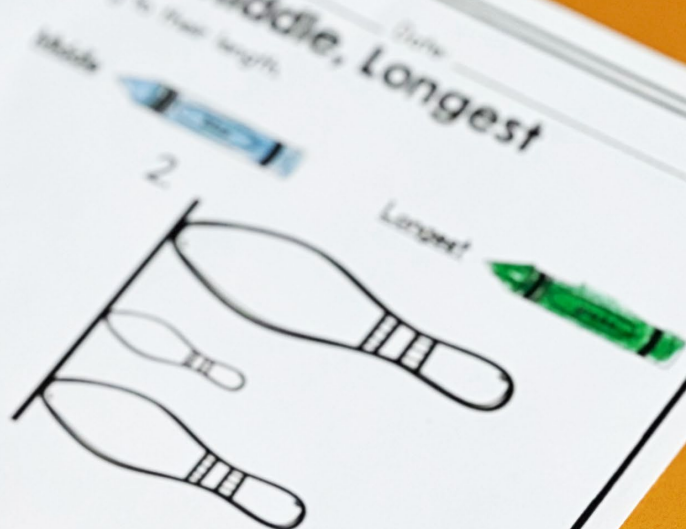



Name: _____ Date: _____

Compare and Order Cut and Paste

Directions: Cut out the objects and order them correctly.

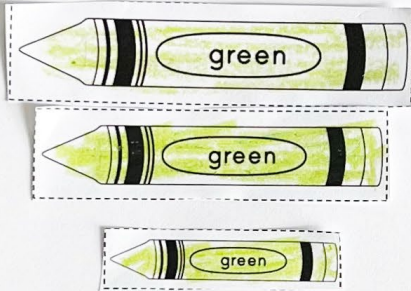
1. Order the  longest to shortest.



2. Order the  longest to shortest.

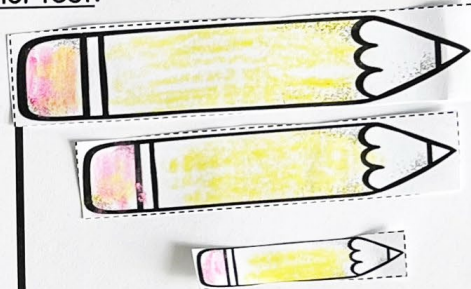

3. Order the  shortest to longest.

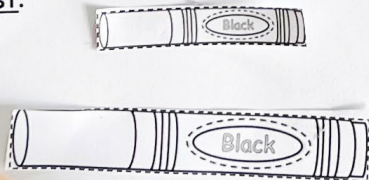

4. Order the  shortest to longest.

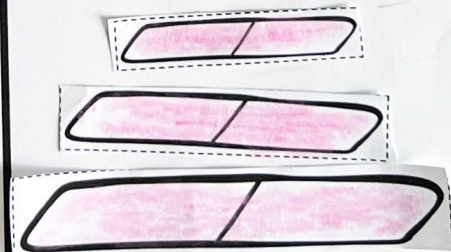

To compare an object's length, we always start the objects at the same endpoint.

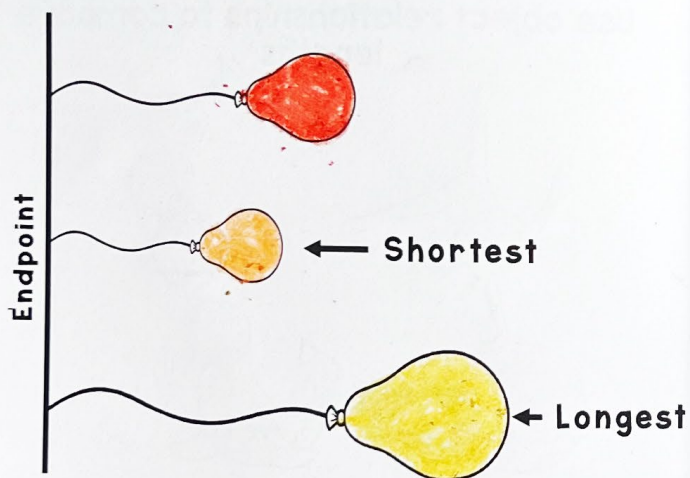

Then, you can identify which objects are the longest and which are the shortest.

©2016 Eureka

We can also use the relationship between objects to help us compare.

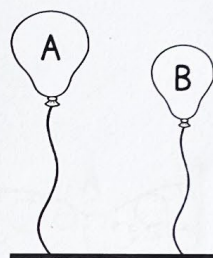

Balloon A is longer than Balloon B

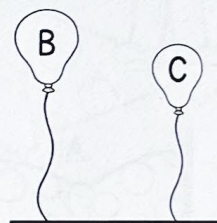

Balloon B is longer than Balloon C

Based on the relationship, we know Balloon A is the longest, and Balloon C is the shortest.

A
LONGEST

B

C
SHORTEST

©2016 Eureka

COMPARE AND ORDER

1. Pedagogy
2. Lesson Plans
3. Vocabulary Cards
4. Song
5. Anchor Chart: Compare and Order
6. Comparing Guided Practice Model Problems
7. Comparing Objects Worksheet
8. Guided Practice Poster Activity
9. Compare and Order Cut and Paste Worksheet
10. Mini-book
11. Caterpillar Compare Poster Activity
12. Caterpillar Independent Practice Worksheet
13. Shortest, Middle, Longest Coloring Worksheet
14. String Measurement Activity
15. Compare and Order Game Center
16. Problem Solver
17. Quiz

Compare and Order Length

When comparing and ordering objects by length, students are beginning to engage in the process of measuring. Students need to build on their understanding of how to make direct and indirect comparisons of lengths in order to advance their grasp of measurement concepts. Through comparing lengths, students are able to understand how to order things by length and evaluate one object's relationship to another. This evaluation is essential to finding success in transitivity. With transitivity, students can use one object's relationship to another to compare the length of an additional object indirectly.

In this unit, students will begin by mastering the concept of comparing lengths, followed by an application of this concept to help them order objects according to their length. As students gain confidence in ordering objects and identifying the longest and shortest, they will be challenged to apply transitivity with two objects by using a third object to offer indirect comparisons. This will be a very hands-on and tactile unit, allowing students to engage deeply with the unit and participate in a permeable way.

Students will gain an understanding of how to compare an object's length with another's, as well as how to order the objects from longest to shortest and shortest to longest. Students will also engage in transitivity to help them make indirect comparisons between an object's length.

Compare and Order Length

Day 1: Introduce comparing and ordering objects by length

Mini Lesson: Introduce the purpose of the lesson today: to compare objects based on length.

- Show students the unit vocabulary cards.
- Watch the Compare and Order Objects Song.
- Introduce the “Compare and Order” Anchor Chart.
- Explain that when we compare lengths, we look at how long or how tall something is.
- Explain and elaborate that we can look at objects and compare their lengths to determine which is longest and which is shortest.
- Model comparing 3 classroom items (perhaps 3 pencils, a pencil, eraser, and a paper clip, etc.). Narrate your comparison process by lining them up at the same endpoint, then narrate as you look at the objects and identify which is the longest and which is the shortest.
- Repeat this with 3 more objects.

Guided Practice: Use the comparing guided practice model; you can display this on the board or projector. As a class, work together to identify which object is the longest and which is the shortest for the two guided practice models.

Independent Practice: Students complete the Comparing Objects worksheet.

Day 2: Comparing and ordering objects by length

Mini Lesson: Introduce the purpose of the lesson today: to compare and order objects by length.

- Watch and sing the Compare and Order Objects Song.
- Review the “Compare and Order” Anchor Chart.
- Explain to students that you will be using the comparing skills they mastered yesterday to order objects according to their length.
- Model comparing 3 objects from the classroom (crayons, markers, pencils, etc.). Narrate identifying which is the longest and which is the shortest. Then, narrate placing them in order from shortest to longest.
- Repeat with 3 more objects.

Guided Practice: Complete the guided practice poster. You will need poster paper and should cut out the guided practice objects beforehand. Call on students to come up and help compare and order the objects.

Independent Practice: Students complete the Compare and Order Cut and Paste worksheet.

Day 3: Compare and order objects through transitivity

Mini Lesson: Introduce the purpose of the lesson today: to compare the length of objects based on the relationship between the objects.

- Review the unit vocabulary cards and the Compare and Order Objects Song.
- Review the “Compare and Order” Anchor Chart.
- Explain to students that you can look at the direct relationship of objects to compare the relationship between 3 objects.
- Model comparing 3 classroom objects, using their relationships to each other to help you compare them all and identify the longest and shortest. Repeat with 3 more objects.
 - i.e., the purple string is longer than the green string. The green string is longer than the orange string. Based on the relationships of the strings, we can determine that the purple string is longer than the orange string.

Guided Practice: Cut up 3 pieces of construction paper. Each paper should be a different color and a different length. As a class, compare paper 1 to paper 2, then paper 2 to paper 3. Using what you know about their relationships, determine paper 1's relationship to paper 3. Repeat again with 3 new pieces of paper if students need more practice.

Independent Practice: Students complete the Comparing Objects Mini-book.

Day 4: Comparing and ordering objects through transitivity

Mini Lesson: Introduce the purpose of the lesson today: to compare the length of objects and order them based on the relationship between the objects.

- Review the unit vocabulary cards and the Compare and Order Objects Song.
- Review the “Compare and Order” Anchor Chart.

Guided Practice: Complete the caterpillar compare poster activity as a class.

Independent Practice: Students complete the caterpillar compare worksheet using the class poster to help.

Day 5: Compare and order objects through transitivity

Mini Lesson: Introduce the purpose of the lesson today: to compare the length of objects using construction paper.

- Review the unit vocabulary cards and the Compare and Order Objects Song.
- Review the “Compare and Order” Anchor Chart.
- Explain that you can compare 3 objects’ lengths indirectly using a third object.
- Model comparing a strip of construction paper to the length of a pencil. Note that the strip of paper is longer than the pencil and the pencil is shorter than the strip of paper. Then, take out an item that is longer than the strip of paper. Note how the length of the strip of paper is shorter than the length of the other item, and that the other item is longer than the strip of paper. The next step is to narrate how you know the pencil is shorter than the strip of paper, but you know the other item is longer than the strip of paper. Because you know this, that means the other item is longer than the pencil, that the pencil is the shortest, the other item is the longest, and the strip of paper is in the middle. Order the items shortest, middle, and longest.
 - Be sure to always narrate how you are lining them all up at the same endpoint before comparing lengths.

Guided Practice: Pass out a strip of construction paper to each student. Ask students to take 3 minutes to use their strip of construction paper to help them find two objects in the classroom, an object shorter than the strip of paper and an object that is longer. Then, ask all the students to return to the carpet with their two objects and strip of paper. Place students in pairs and have them work together, using their strip of construction paper, to order their communal objects from shortest to longest. Circle to check work, and have a few groups share out their order.

Independent Practice: Students complete the Shortest, Middle, Longest worksheet.

Day 6: Compare and order objects through transitivity

Mini Lesson: Introduce the purpose of the lesson today: to compare the length of objects using string.

- Review the unit vocabulary cards and the Compare and Order Objects Song.
- Review the “Compare and Order” Anchor Chart.
- Remind students that you can compare 3 objects’ lengths indirectly using a third object. Remind them of the construction paper activity from the day before.
- Explain that today you will be using string to help you determine the length of items and then compare their lengths.
- Model using a string to help you determine the length and order of three items. You can model pinching the string where the length of the object ends, then keeping it pinched as you measure the next object. This helps you to compare lengths using the string instead of having to move the object. Then, measure the final object. When you have used the string to help you determine lengths, compare them and place the objects in order from longest, middle, and shortest.
 - Be sure to note how you are lining the string and the item up at the same endpoint before you measure.
- Repeat the model with 3 additional items.

Guided Practice: Present the class with 3 new items. Call students up to use the string to measure each object. Then, have the class help you place the items in order of longest, middle, and shortest.

Independent Practice: Place students in small groups. Pass out a small spool of string to each group and have students complete the String Measurement Activity.

Day 7: Review comparing and ordering by length

Mini Lesson: Introduce the purpose of the lesson today: to compare and order objects based on length.

- Review the unit vocabulary cards and the Compare and Order Objects Song.
- Review the “Compare and Order” Anchor Chart.
- Teach the Compare and Order Game Center.

Day 7 continued . . .

Guided Practice: Students play the Compare and Order Game in small groups.

Independent Practice: Students complete the problem solver.

Day 8: Compare and order objects by length

Mini Lesson: Introduce the purpose of the lesson today: to compare the length of objects using construction paper.

- Review the unit vocabulary cards and the Compare and Order Objects Song.
- Review the “Compare and Order” Anchor Chart.

Guided Practice: Optional to have students complete the review center from the day before.

Independent Practice: Compare and Order Objects by Length Quiz

Compare and Order

Compare and order, compare and order
Measure each size then put them in order
Compare and order, compare and order
Compare the lengths and then put them in order



Line everything from end to end
Measuring them from the starting
Compare each size as you go down the row
And then order them how they are supposed to go

Compare and order, compare and order
Measure each size then put them in order
Compare and order, compare and order
Compare the lengths and then put them in order

No overlaps and no gaps
Put them shortest to longest if you want to do that
Or maybe long to short it's up to you
But comparing and order is what to need to do

Compare and order, compare and order
Measure each size then put them in order
Compare and order, compare and order
Compare the lengths and put them in order

Compare and order, compare and order
Measure each size then put them in order
Compare and order, compare and order
Compare the lengths and then put them in order

Now Stop

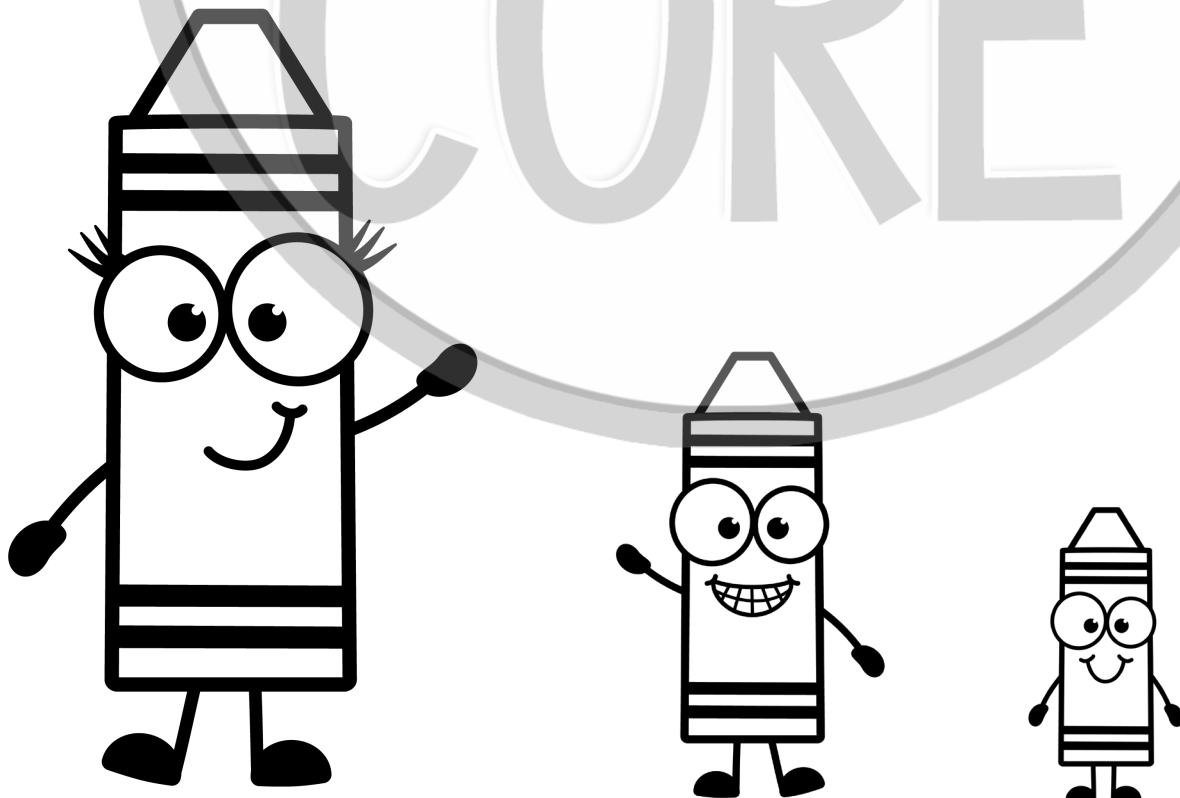

Compare and Order

When we order objects by length, we have to compare their lengths to know how to order them!

COMPARE

1. Line everything up at the same **endpoint**.

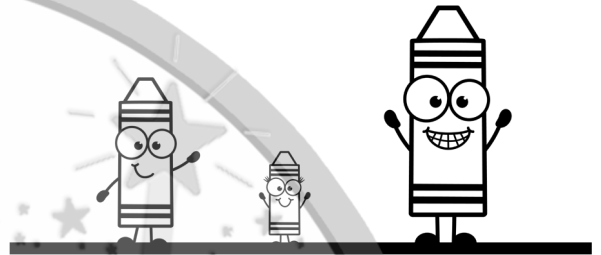

2. Measure from **endpoint to endpoint**.

LONGEST



SHORTEST



ORDER

3. Longest to Shortest
OR
Shortest to Longest

LONGEST

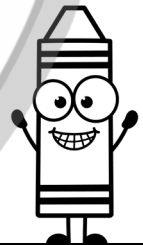

SHORTEST



NO overlaps or gaps!

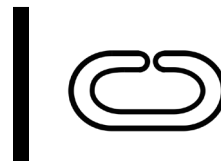

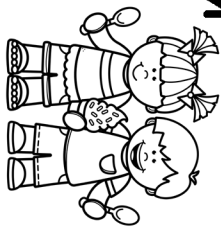

Name: _____

Date: _____

Comparing Objects

Directions: Identify the longest object and the shortest object. Write its number under longest

or shortest.

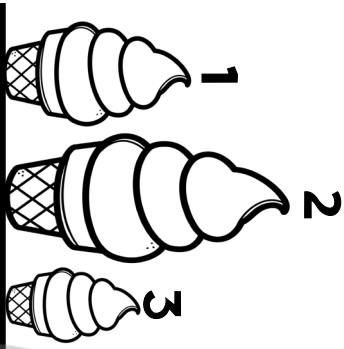
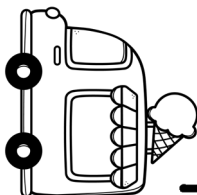

Which is the longest? Which is the shortest?

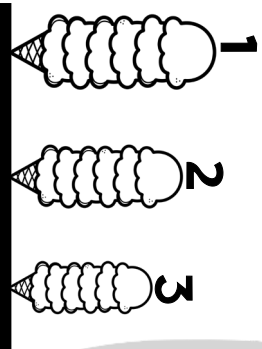

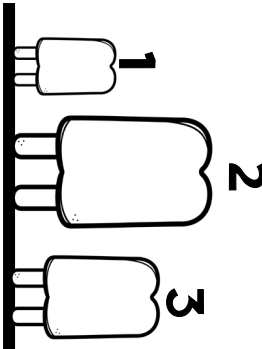

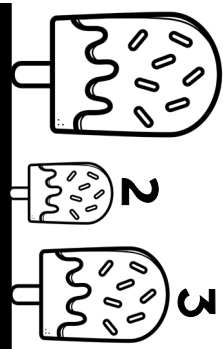

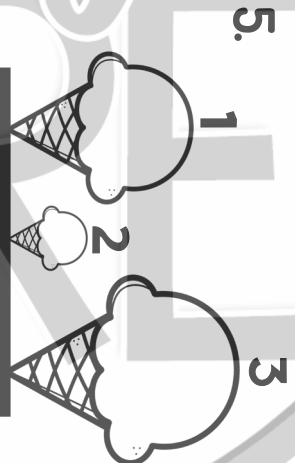

Which is the longest? Which is the shortest?

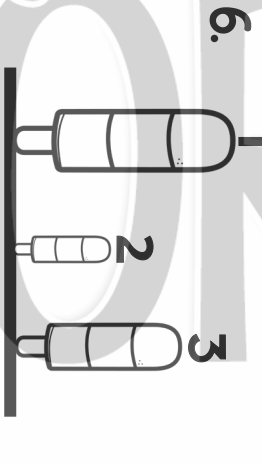

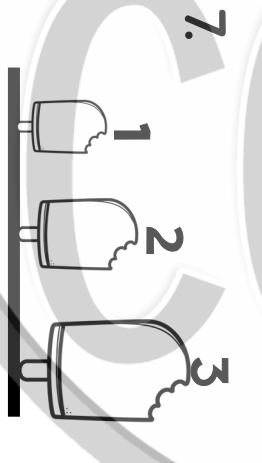

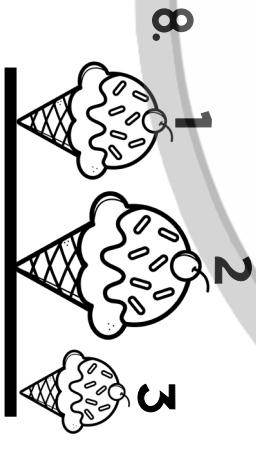

Name: _____ Date: _____

Compare and Order Cut and Paste

Directions: Cut out the objects and order them correctly.

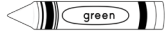

1. Order the crayons longest to shortest.



2. Order the pencils longest to shortest.



3. Order the markers shortest to longest.



4. Order the erasers shortest to longest.

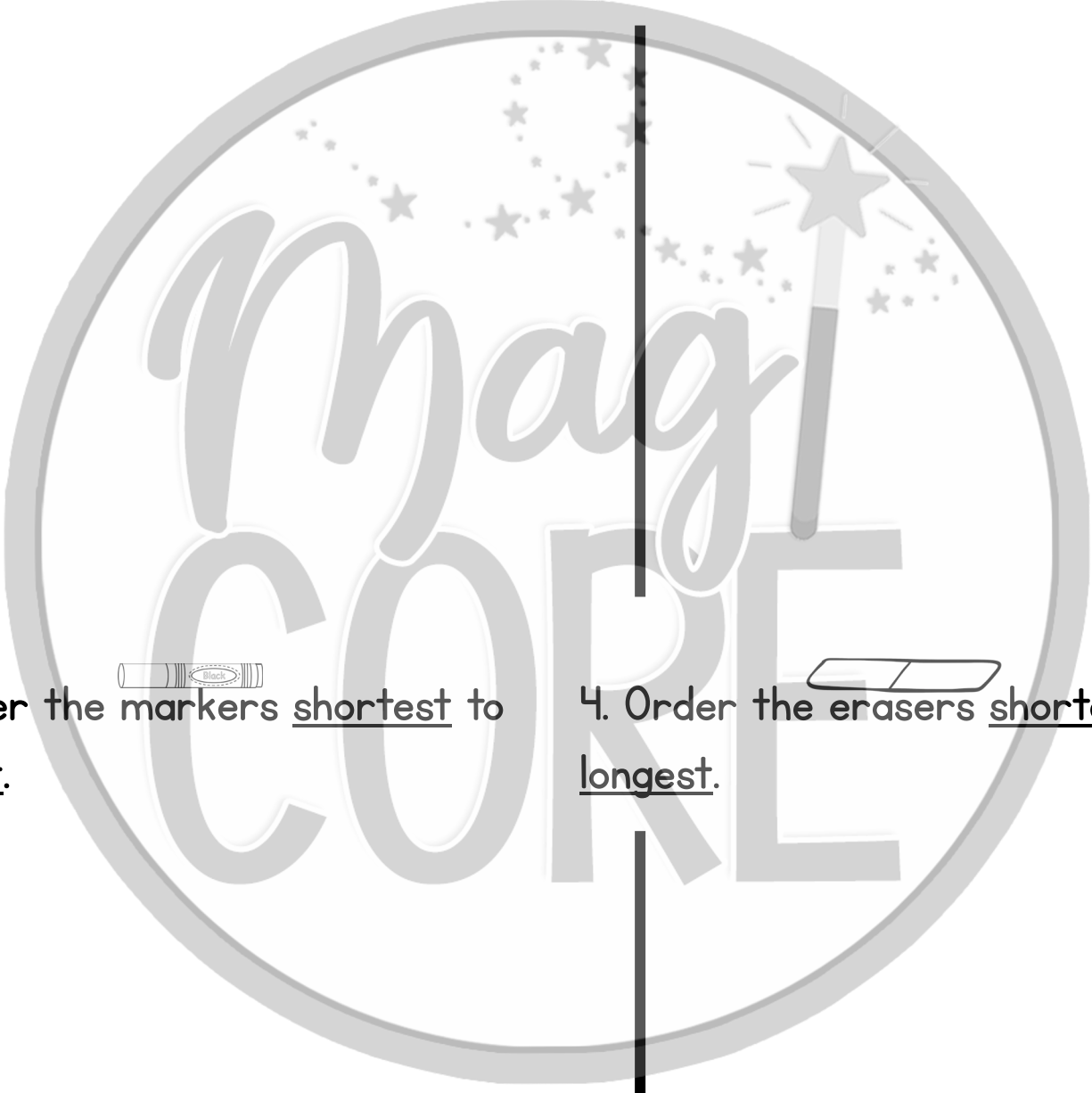

Directions:

Cut out the set of objects and glue them in the correct order on your worksheet.

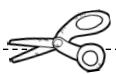

Directions:

Cut out the set of objects and glue them in the correct order on your worksheet.

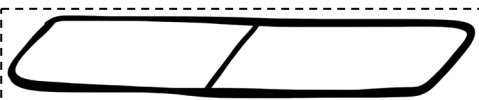
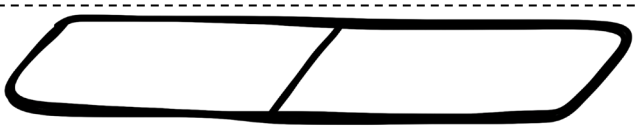
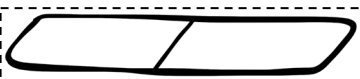
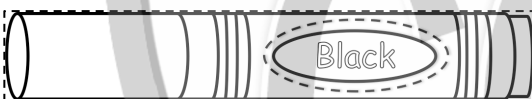
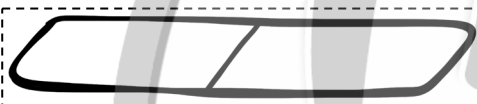
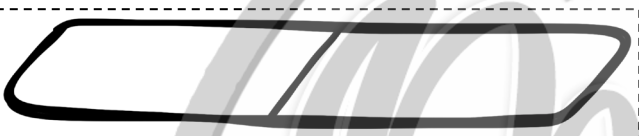
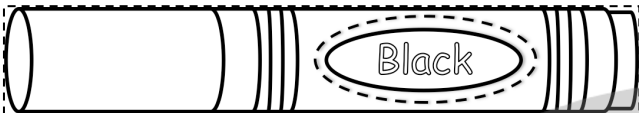
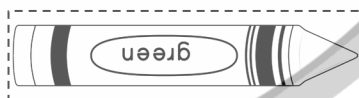
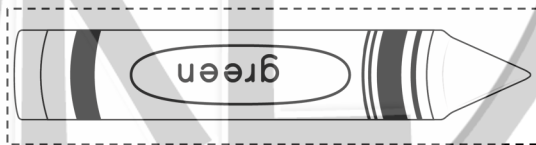
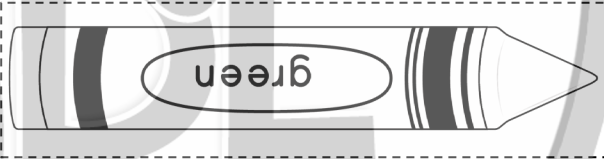
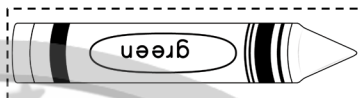
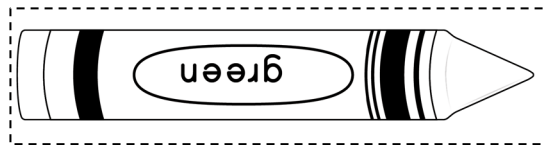
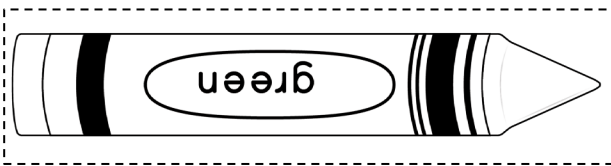

The Object Circus

Use object relationships to compare lengths



By: _____

Date: _____

To compare an object's length,
we always start the objects at
the same endpoint.

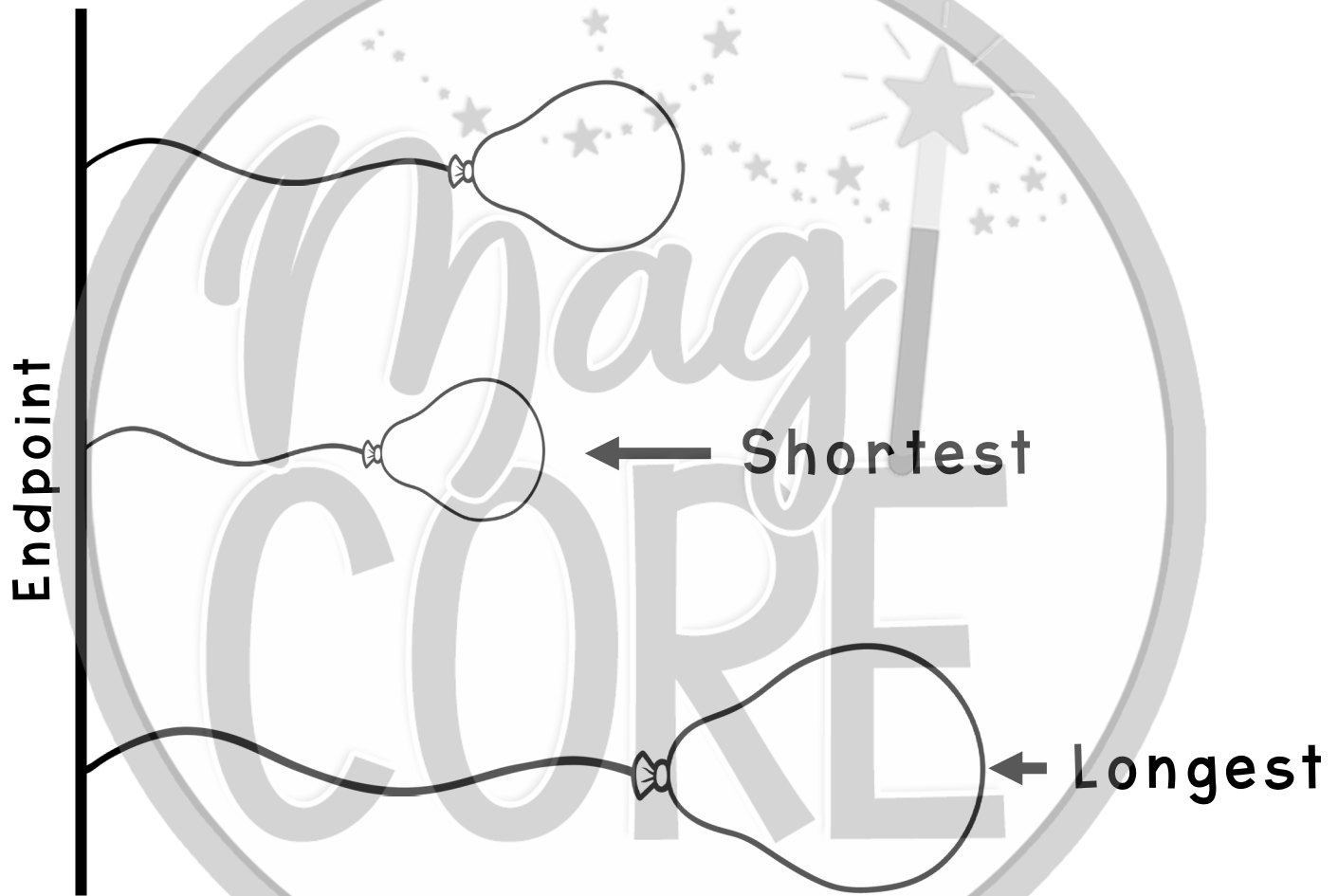

Then, you can identify which
objects are the longest and
which are the shortest.

We can also use the relationship between objects to help us compare.



Balloon A is longer than
Balloon B

Balloon B is longer than
Balloon C

Based on the relationship, we know Balloon A is the longest, and Balloon C is the shortest.

A

LONGEST

B

C

SHORTEST



Use what you know about the relationships between the bowties to order the objects from shortest to longest.

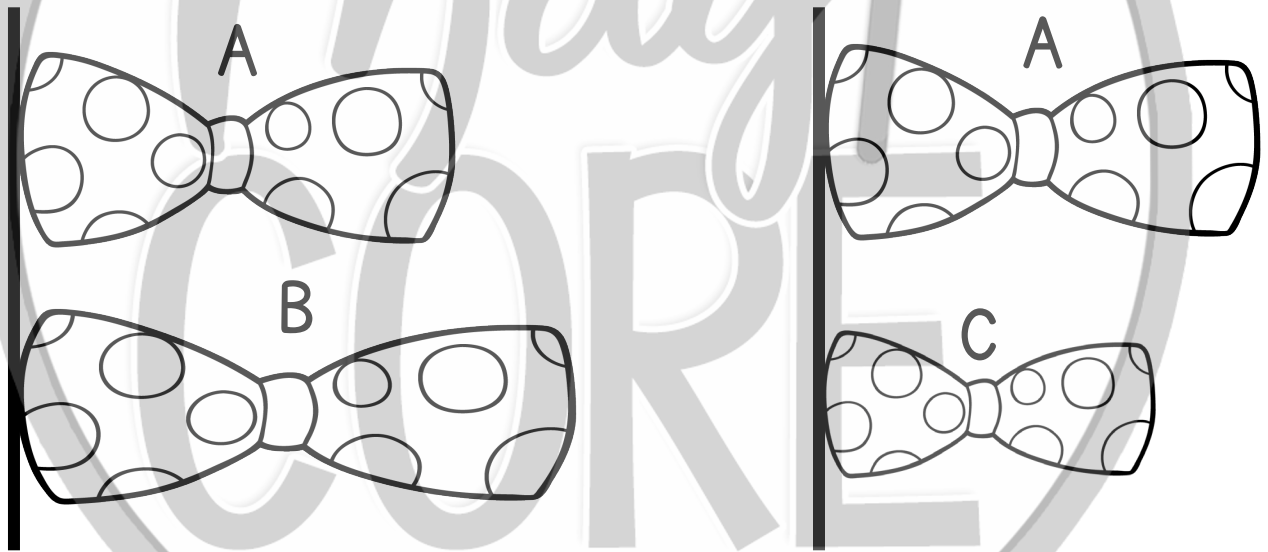

SHORTEST



LONGEST

Caterpillar Compare Poster Activity

Directions:

1. You will be using the poster you put together to help students solve their questions on the independent practice worksheet.
2. Print off and cut out each caterpillar.
3. Print and post the poster model in class or project on the board.
4. Pass out caterpillars A, B, and C to three students.
5. Have each child come up and help tape the three caterpillars in order from longest caterpillar to shortest caterpillar. Have them place them all on an endpoint to compare lengths to help determine the order.
6. Once they have completed ordering A, B, and C, pass out caterpillars D, E, and F to three new students.
7. Repeat the comparing and ordering process with D, E, and F but for shortest to longest.
8. Students will then use this class poster to help them complete their independent worksheets.

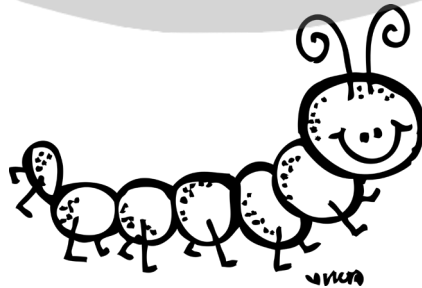

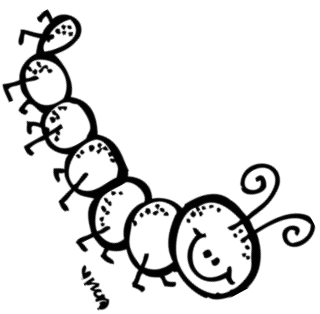

Caterpillar Poster

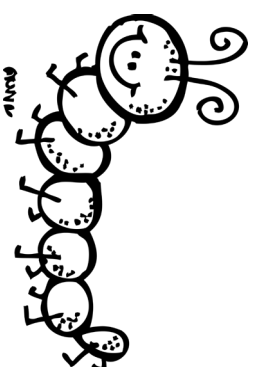

LONGEST

SHORTEST

SHORTEST

LONGEST

Magi
CORE

Name: _____ Date: _____

Shortest, Middle, Longest

Directions: Color the object according to their length.

Shortest



Middle



Longest

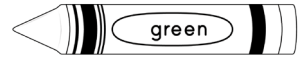

1.

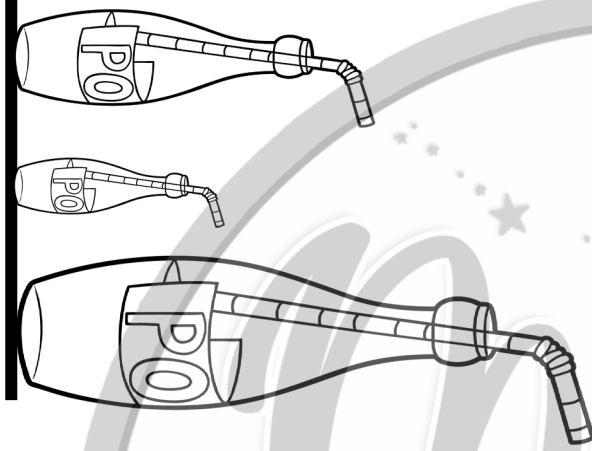

2.



3.

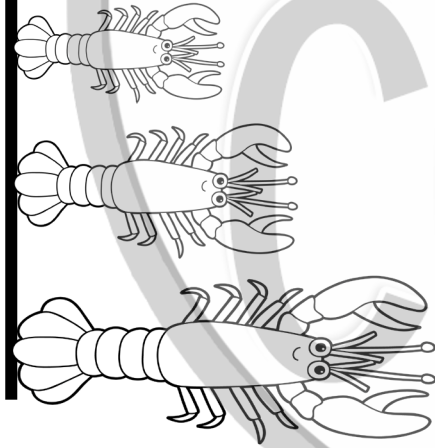

4.

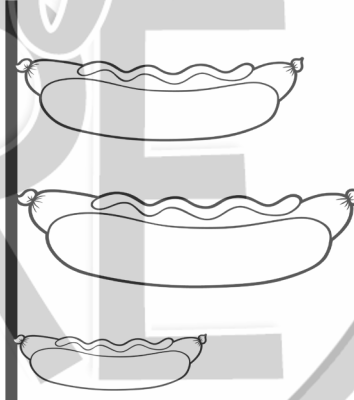

5.

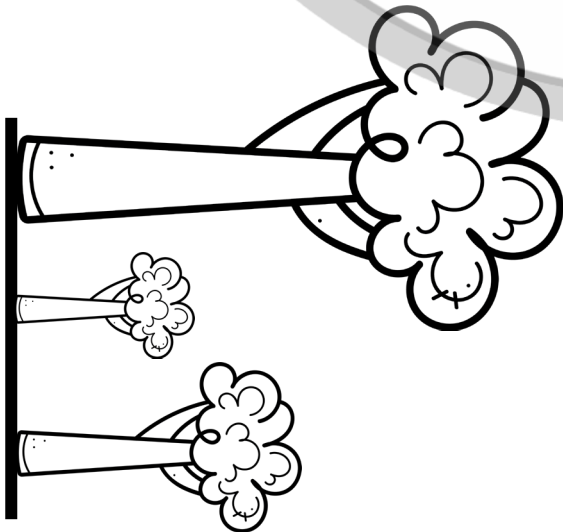

6.

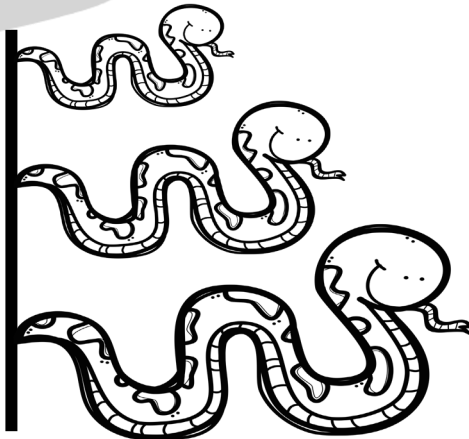

String Measurement Activity

Directions:

1. Print out enough String Measurement Scavenger Hunt lists for each group of students. Students should be in groups of 3-4.
2. Assemble a small spool of yarn for each group.
3. Make sure each group has a scavenger hunt list, a spool of yarn, and a pair of scissors.
4. Groups will go around and measure the objects on their list, cutting the string to the length of each object.
5. When groups have the string length of each object on the list, they must compare the string lengths and order them from longest to shortest.

Group Names: _____

String Measurement Scavenger Hunt

Directions: Measure the objects on the list using your string. Cut a piece of string the length of each object. Then, order your strings from longest to shortest and write the order at the bottom.

Items

Desk

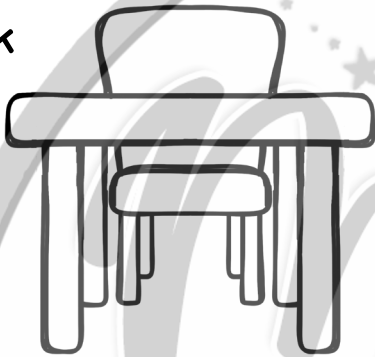

Paperclip



Journal



Marker



Pencil



LONGEST

SHORTEST

Compare and Order Game

Directions:

1. Print all objects
2. Laminate and cut out.
3. Place the items in a large Ziploc bag with a single quarter.
4. Individually or with a partner, students will draw 3 object cards out of the bag. Then, they flip the quarter. If the quarter lands on "heads," they need to order the objects from longest to shortest. If the quarter lands on "tails," they need to order the objects from shortest to longest.
5. If you want to save paper, the other option is to fill the bags with classroom items. Students can pick out 3 items and order them by length.

Label

Compare and Order Game

Longest



Shortest



Directions: Pick 3 objects from the bag and compare their lengths. Then, flip a coin to determine how to order them. Heads - order from longest to shortest. Tails - order from shortest to longest.

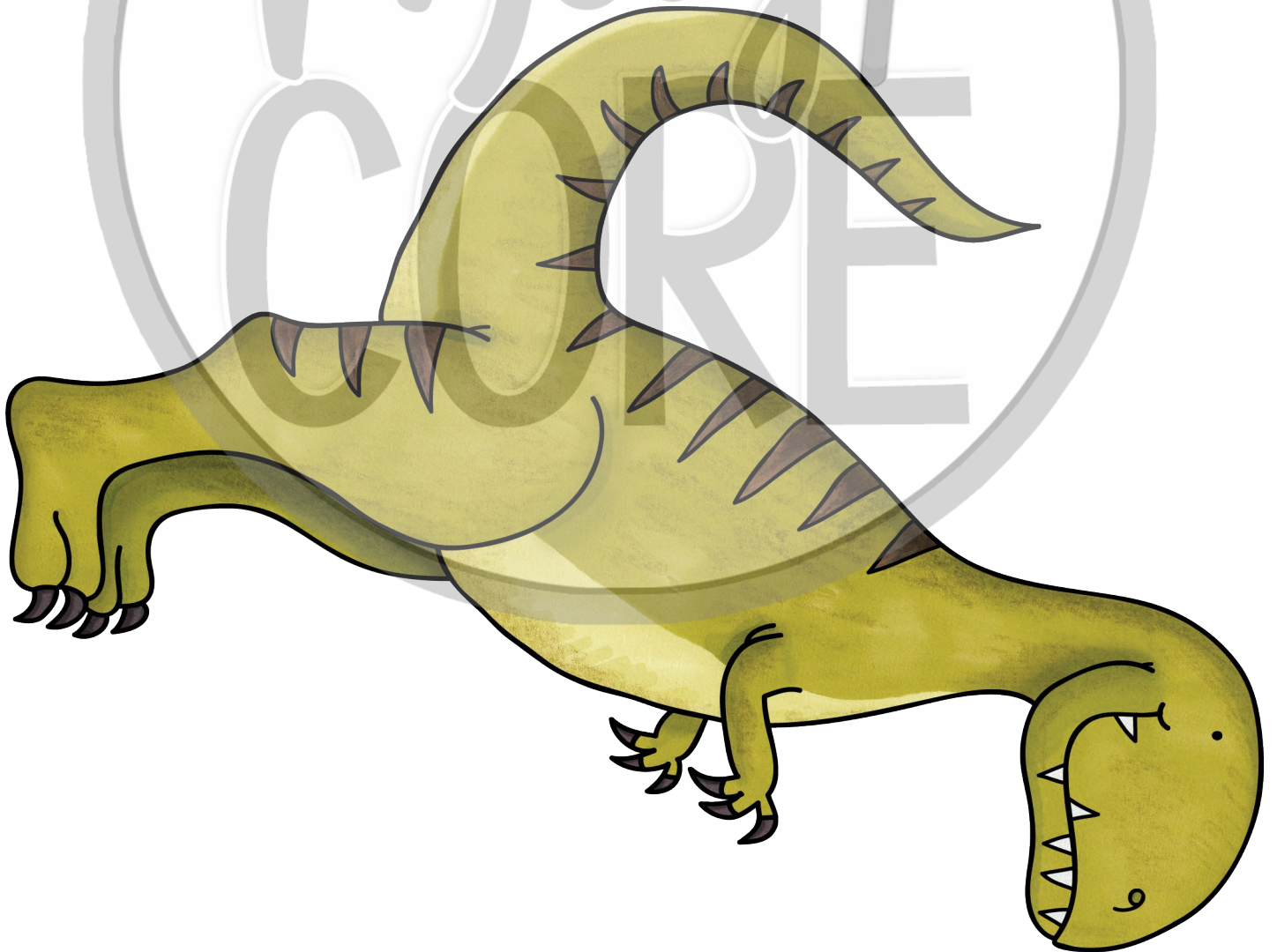
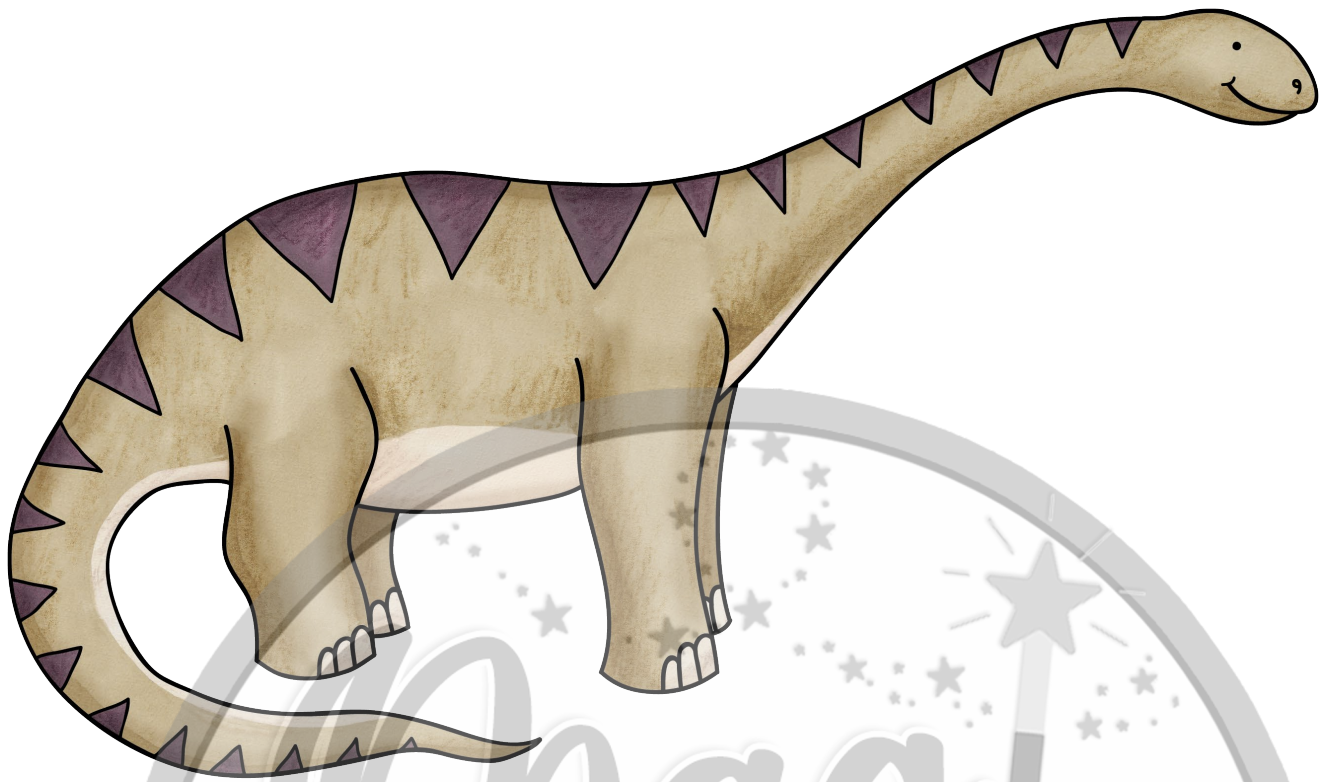

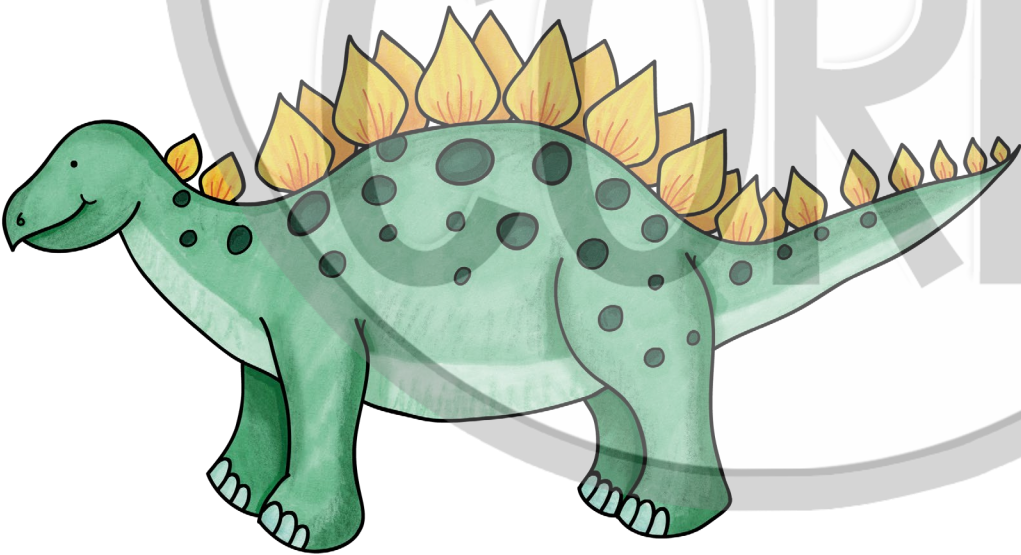
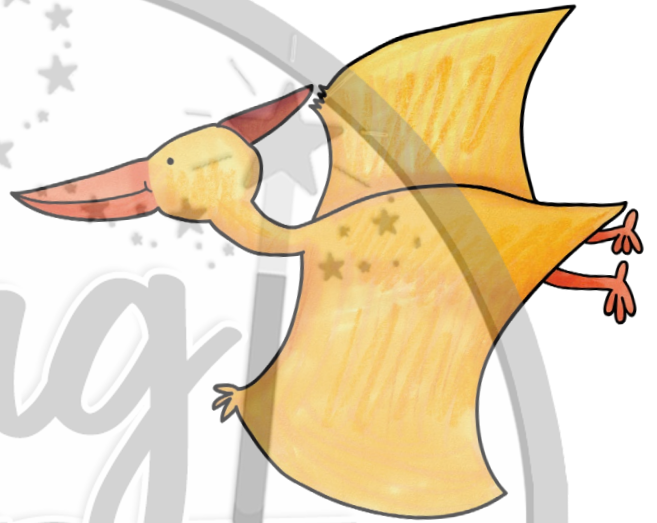
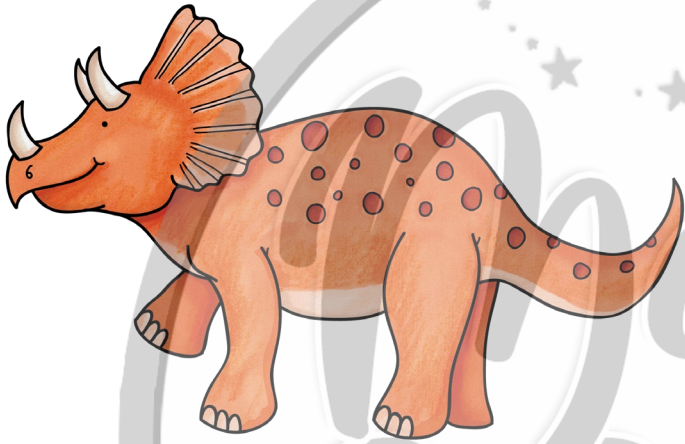
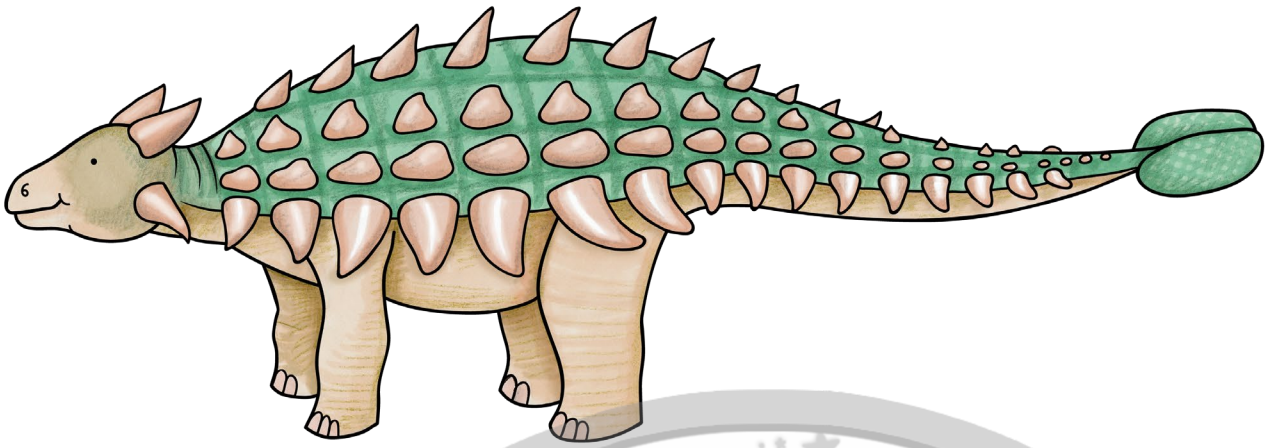

COAGI
CORE

Name: _____ Date: _____

Problem Solver

Solve the word problems. Write the objects from the word problem in the correct order.

1. Miranda is cutting ribbon for her little sister's birthday party. The yellow ribbon is shorter than the purple ribbon, and the purple ribbon is shorter than the green ribbon. Order Miranda's ribbon from longest to shortest.



2. Simon has 3 pencils he wants to order by length. His plain pencil is longer than his sparkly pencil, and his sparkly pencil is longer than his spotted pencil. Order Simon's pencils from shortest to longest.



Terms of Use



How Can I Use This Resource?

Thank you for trusting MagiCore. Our mission is to create resources that support teachers and promote student success. Please note that this resource is licensed for use by a single teacher in a classroom setting. If you need to use this resource with more than one teacher and/or across multiple classrooms, additional licenses are available at a discount. You can purchase additional licenses by visiting your TPT "Purchases" page and then selecting "Download Additional Licenses" or by contacting me at julie@magicorelearning.com.



Good to Go



Not O.K.

- Use this resource personally or with your own children.
 - Use this resource in your own classroom with your students.
 - Provide this resource to your students to use at your instruction.
 - Print and/or copy for use in your own classroom.
 - Provide printed pages to a substitute teacher with the sole purpose of instructing your students.
 - Share with your students via a secure document portal or electronic learning platform that requires individual user verification and limits access to only the students in your own classroom (e.g. Google Classroom).
 - Review this resource with others with the sole purpose of recommending it to others for purchase, provided you share one of the links below:
- <https://magicorelearning.com/>
 - <https://www.teacherspayteachers.com/Store/Magicore>
 - Share with others to use personally.
 - Share with others to use in another classroom.
 - Print or copy any page(s) and distribute them to other teachers or other classrooms.
 - Publish or host online in a manner where any of the material is accessible to anyone who is not a student in your own classroom, including but not limited to personal, classroom, or district websites that are accessible to the general public.
 - Use this resource commercially (e.g. Outschool).
 - Publish, sell, or otherwise distribute this product to anyone in manner inconsistent with these terms of use.

LET'S CONNECT!



LOOKING FOR MORE?

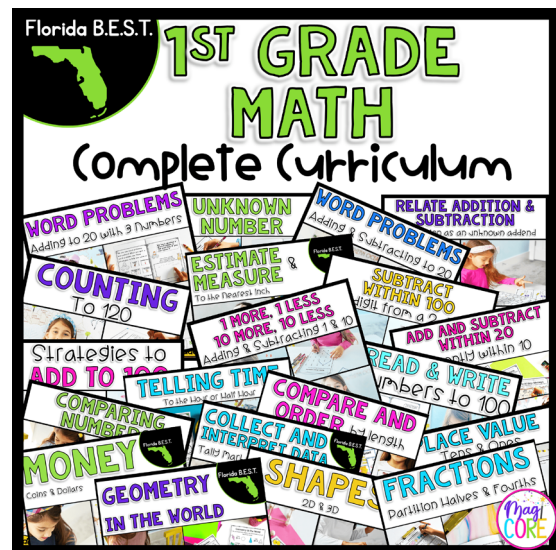
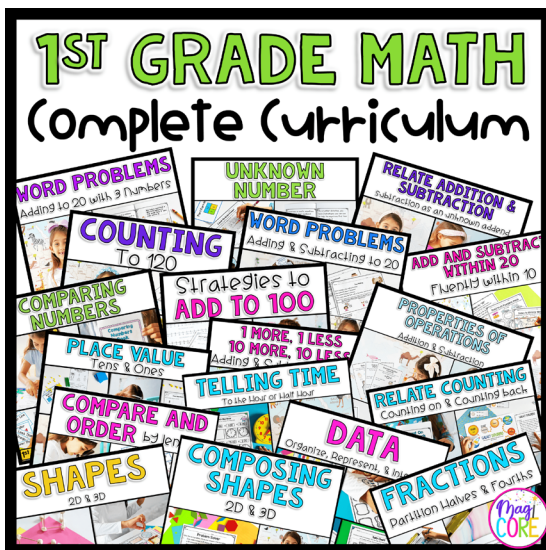

www.magicorelearning.com



DID YOU ENJOY THIS RESOURCE?

LEAVE US A REVIEW ON TPT



Reviews help other teachers know if this resource is a good fit for them.

Reviews also help our resources show up when teachers search!

- Head over to My Purchases to leave a review!
- Have a question? Have a problem with the resource? You can reach out to me directly so I can make it right.



[CLICK HERE TO LEAVE A REVIEW!](#)



CREDITS

www.scrappindoodles.com

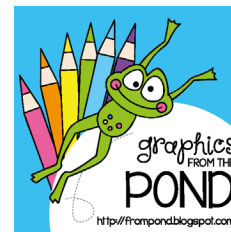

www.magicorelearning.com